

R:\Clients\Clark Hall Iron Doors PERMANENT\A - Florida Product Approvals\FL-16663 Exterior Doors - Iron Doors\C - Drawings\FL 16663 (2014)\FL-16663.4-6.dwg, FL-16663.5

Clark Hall Iron Doors

GLAZED IRON DOUBLE DOOR w/ & w/out SIDELITES

INSWING/OUTSWING "NON-IMPACT"

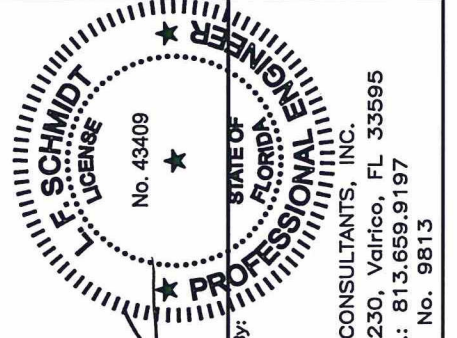

Documents Prepared By:
Lyndon F. Schmidt
P.E. No. 43409

RW BUILDING CONSULTANTS, INC.
P.O. Box 230, Valrico, FL 33595
Phone No.: 813.659.9197
FBPE C.A. No. 9813

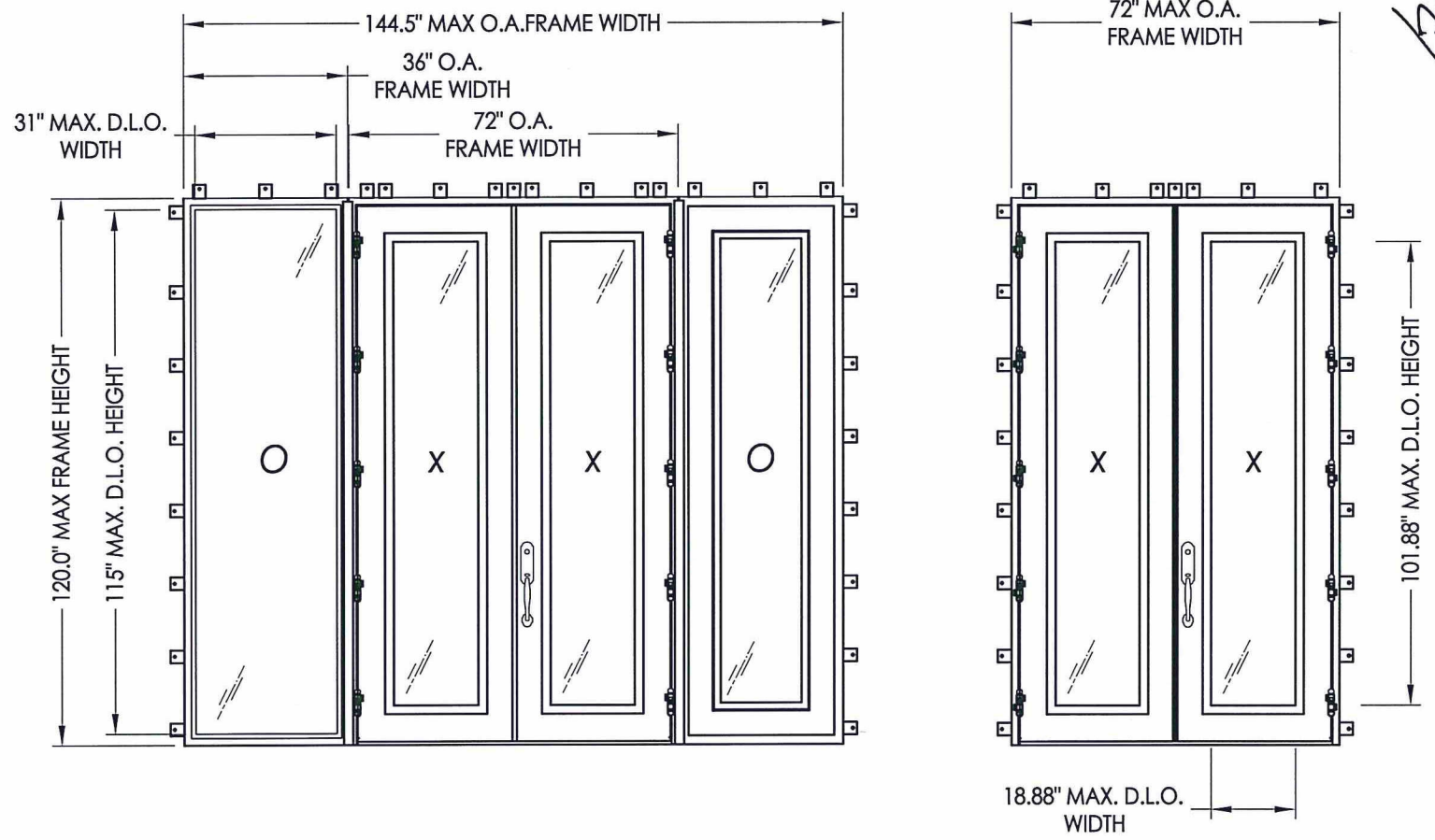

GENERAL NOTES

1. This product has been evaluated and is in compliance with the 5th Edition (2014) Florida Building Code (FBC) structural requirements excluding the "High Velocity Hurricane Zone" (HVHZ).
2. Product anchors shall be as listed and spaced as shown on details. Anchor embedment to base material shall be beyond wall dressing or stucco.
3. When used in areas requiring wind borne debris protection this product is required to be protected with an impact resistant covering that complies with Section 1609.1.2 of the FBC.
4. For 2x stud framing construction, anchoring of these units shall be the same as that shown for 2x buck masonry construction.
5. Site conditions that deviate from the details of this drawing require further engineering analysis by a licensed engineer or registered architect.

TABLE OF CONTENTS	
SHEET#	DESCRIPTION
1	Typical elevations, design pressures, & general notes
2	Door panel details
3	Sidelite panel details
4	Glazing details
5	Elevations
6	Horizontal cross sections
7	Vertical cross sections
8	Buck anchoring
9	Frame anchoring
10	Frame anchoring
11	Components
12	Bill of materials & components

CONFIGURATION	OVERALL FRAME DIMENSION	DESIGN PRESSURE (PSF)			
		INSWING		OUTSWING	
		POS.	NEG.	POS.	NEG.
XX	72.0" x 120.0"	+65.0	-65.0	+65.0	-65.0
OXXO	144.5" x 120.0"	+65.0	-65.0	+65.0	-65.0

PRODUCT: CLARK HALL IRON DOORS		PART OR ASSEMBLY: TYPICAL ELEVATIONS, DESIGN PRESSURES & GENERAL NOTES	
NO.	DATE	BY	REVISIONS
1	8/17/15	LFS	UPDATE TO 5TH ED. (2014) FBC
DATE: 10/30/13			
SCALE: N.T.S.			
DWG. BY: JK			
CHK. BY: LFS			
DRAWING NO.: FL-16663.5			
SHEET 1 OF 12			

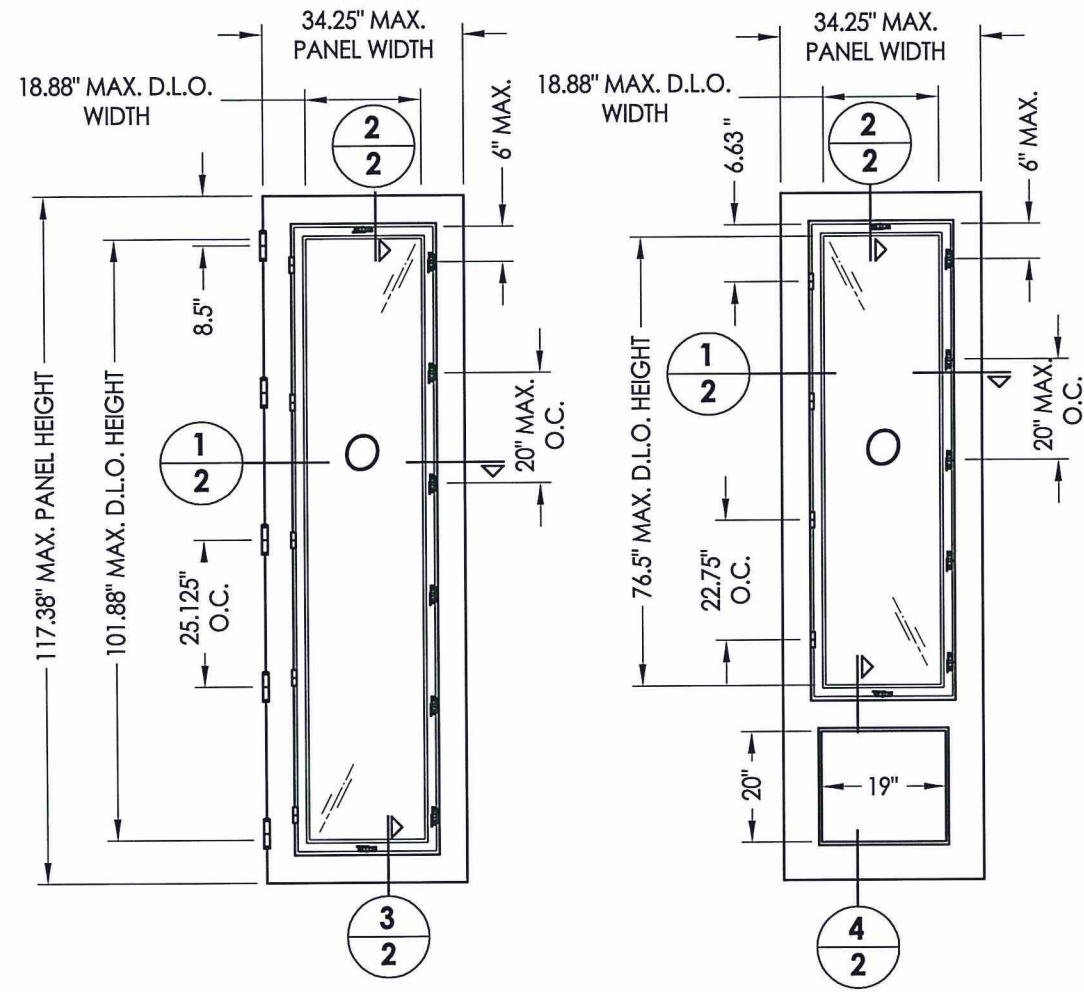

30 DOOR PANEL
w/ Operable Sash

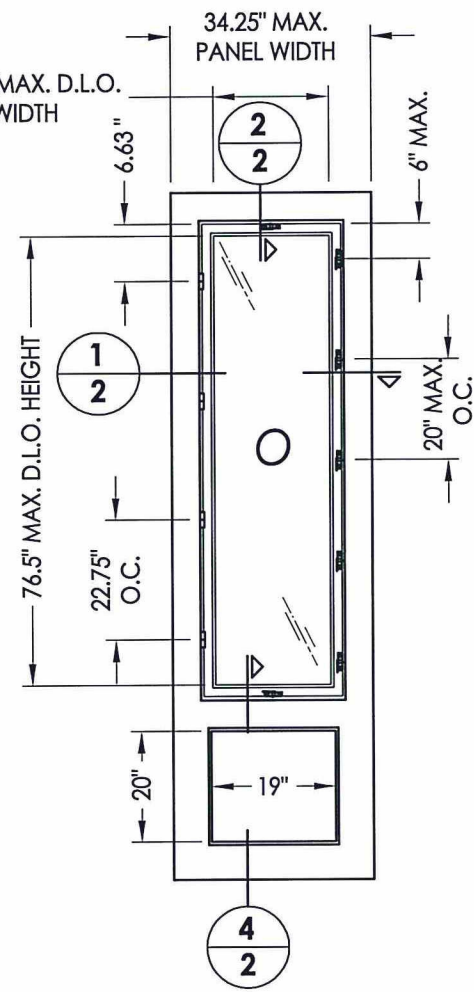

40 3/4 LITE DOOR PANEL
w/ Operable Sash

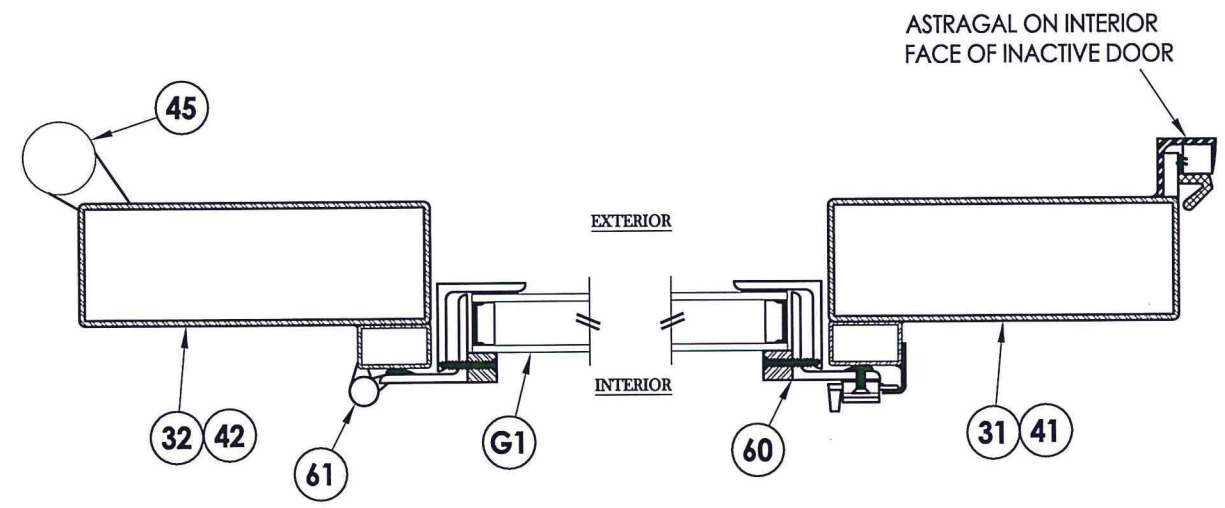

1 HORIZONTAL CROSS SECTION
2 Active Door Panel Shown

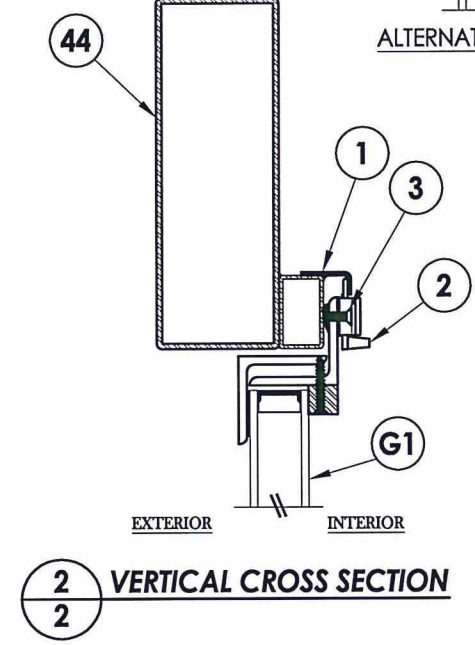

2 VERTICAL CROSS SECTION

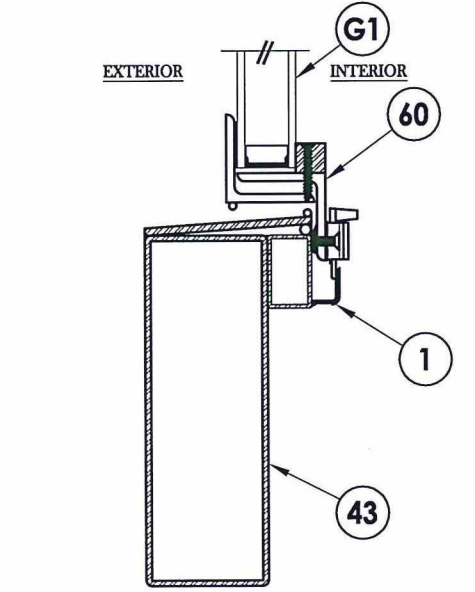

3 VERTICAL CROSS SECTION

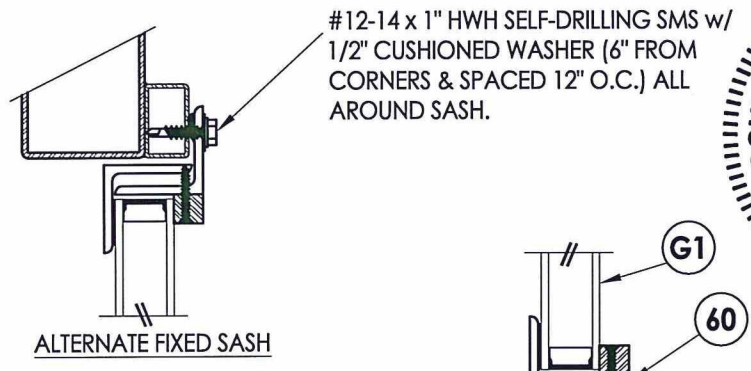

ALTERNATE FIXED SASH

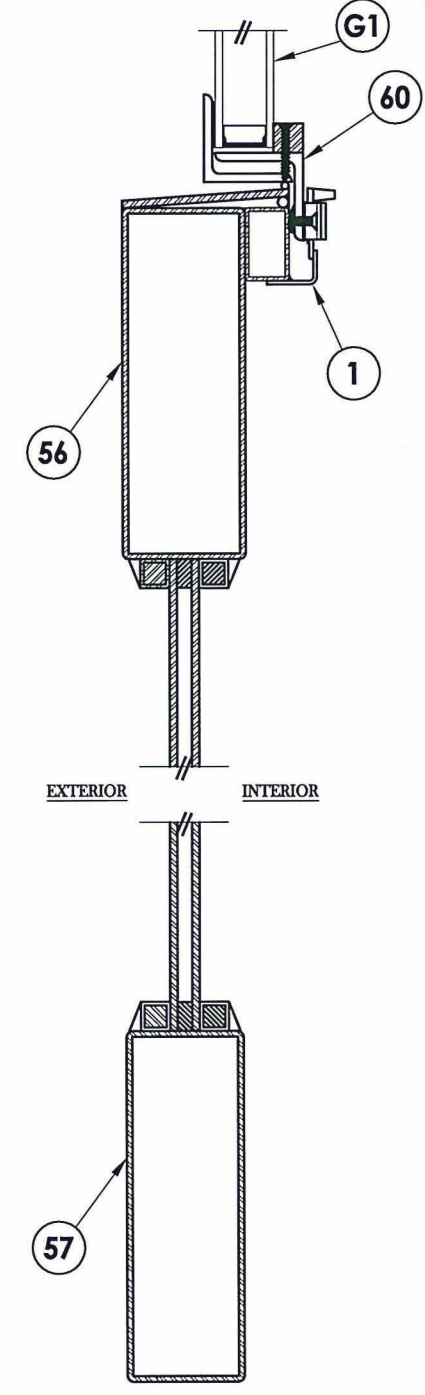

4 VERTICAL CROSS SECTION

Documents Prepared By:
 Lyndon F. Schmidt
 P.E. No. 43409

BUILDING CONSULTANTS, INC.
 P.O. Box 230, Valrico, FL 33595
 Phone No.: 813.659.9197
 FBPE C.A. No. 9813

PRODUCT: CLARK HALL IRON DOORS		PART OR ASSEMBLY: DOOR PANEL DETAILS	
DATE: 11/8/13		SCALE: N.T.S.	
DWG. BY: JK		CHK. BY: LFS	
DRAWING NO.: FL-16663.5		REVISIONS	
NO.	DATE	BY	
1	8/17/15	LFS	UPDATE TO 5TH ED. (2014) FBC

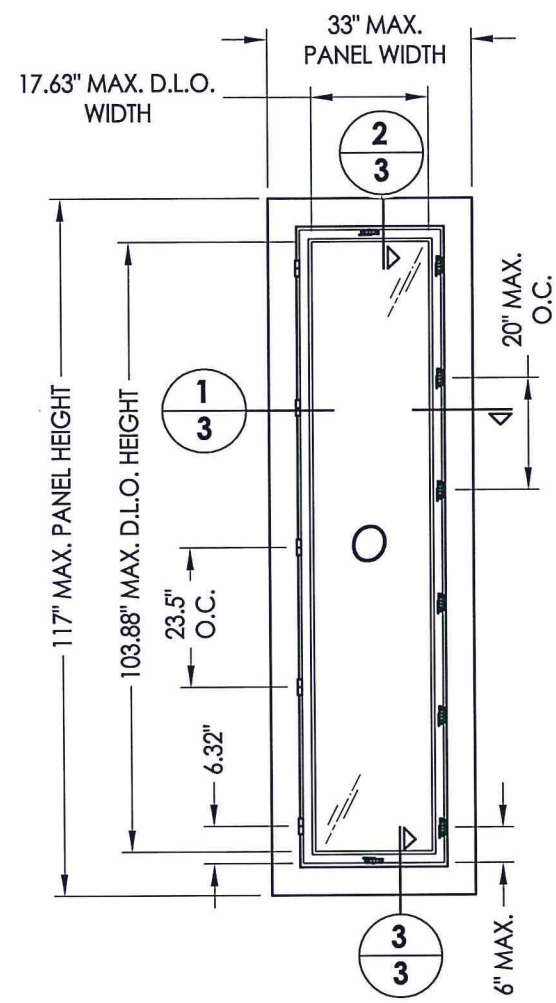

50 SIDELITE PANEL
w/ Operable Sash

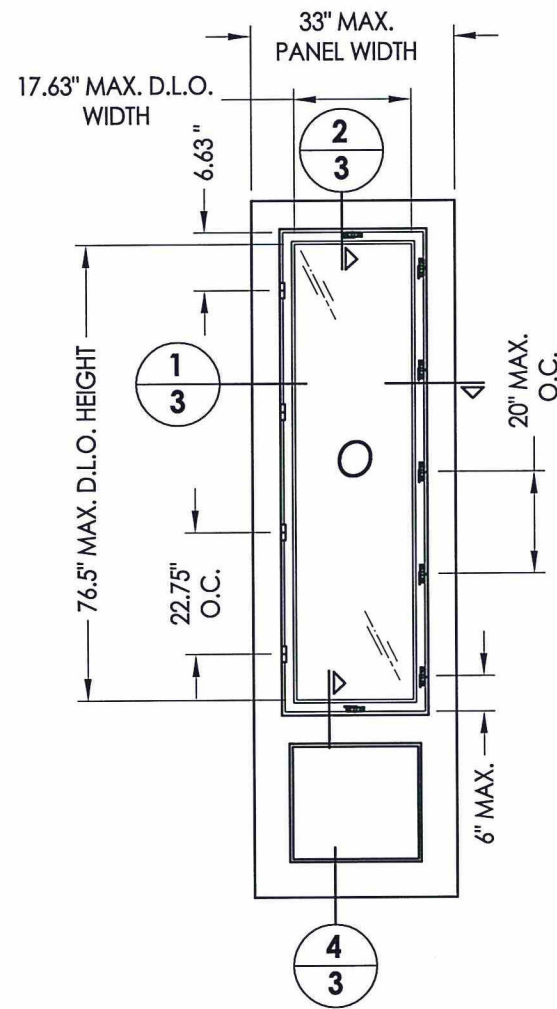

55 3/4 SIDELITE PANEL
w/ Operable Sash & Fixed Panel

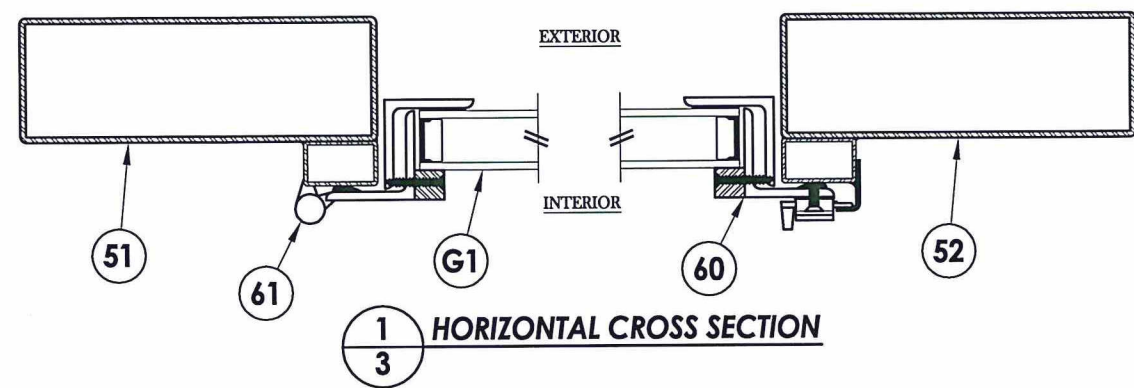

1 HORIZONTAL CROSS SECTION

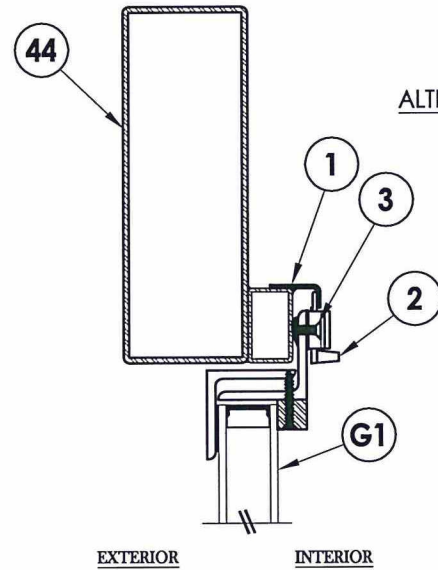

2 VERTICAL CROSS SECTION

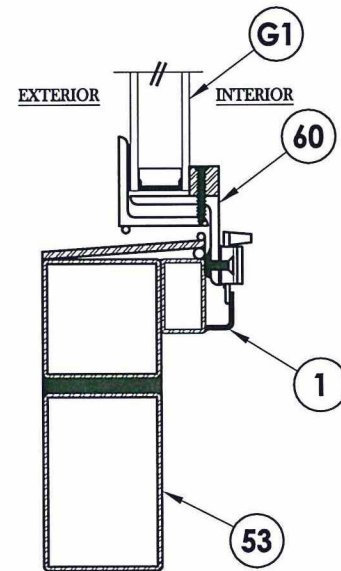

3 VERTICAL CROSS SECTION

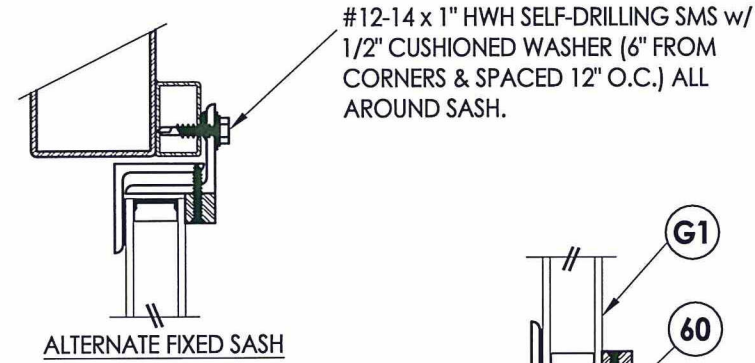

ALTERNATE FIXED SASH

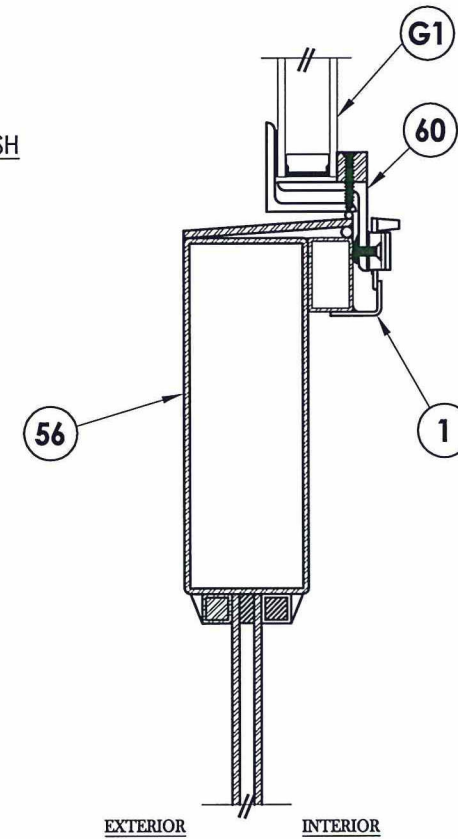

4 VERTICAL CROSS SECTION

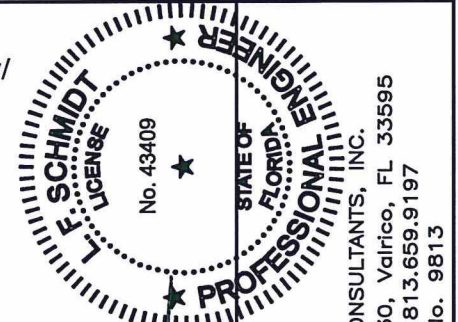

LFR
8-18-15

Documents Prepared By:
Lyndon F. Schmidt
P.E. No. 43409

R.W. BUILDING CONSULTANTS, INC.
P.O. Box 230, Vairico, FL 33595
Phone No.: 813.659.9197
FBPE C.A. No. 9813

PRODUCT:		CLARK HALL IRON DOORS	
PART OR ASSEMBLY:		SIDELITE PANEL DETAILS	
NO.	DATE	BY	REVISIONS
1	8/17/15	LFS	UPDATE TO 5TH ED. (2014) FBC
DATE:		11/8/13	
SCALE:		N.T.S.	
DWG. BY:		JK	
CHK. BY:		LFS	
DRAWING NO.:		FL-16663.5	
SHEET		3 OF 12	

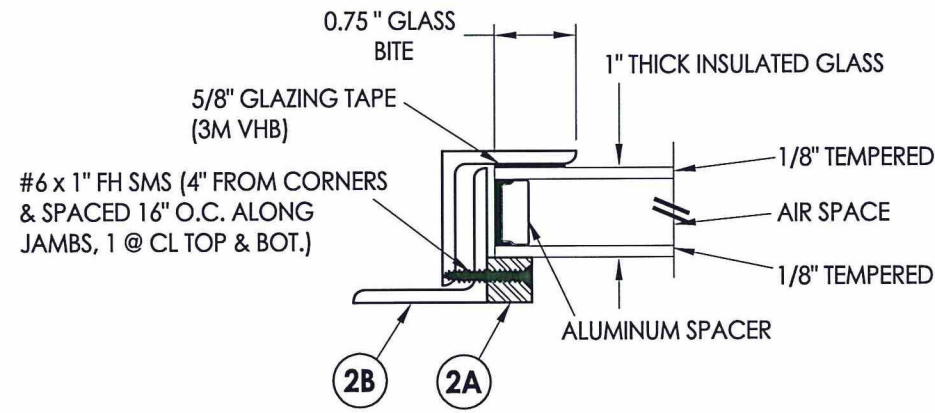

G1 GLAZING DETAIL
Operable Door/Sidelite

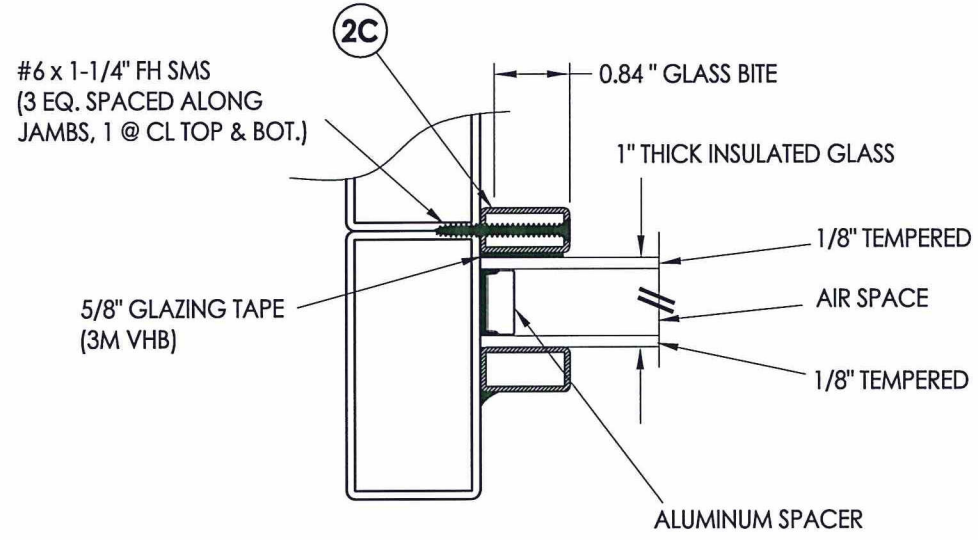

G1 GLAZING DETAIL
Fixed Sidelite/Transom

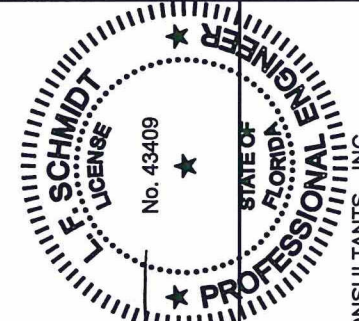
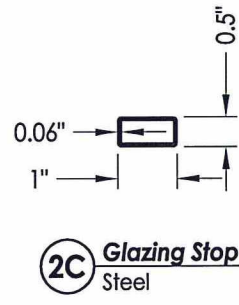
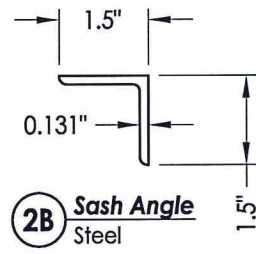
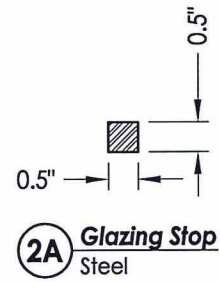

LFS
5-18-15

Documents Prepared By:
Lyndon F. Schmidt
P.E. No. 43409

R.W.
BUILDING CONSULTANTS, INC.
P.O. Box 230, Valrico, FL 33595
Phone No.: 813.659.9197
FBPE C.A. No. 9813

PRODUCT: CLARK HALL IRON DOORS
PART OR ASSEMBLY: GLAZING DETAILS

NO.	DATE	DESCRIPTION	LFS	BY
1	8/17/15	UPDATE TO 5TH ED. (2014) FBC	LFS	BY

DATE: 11/8/13
SCALE: N.T.S.
DWG. BY: JK
CHK. BY: LFS
DRAWING NO.: FL-16663.5
SHEET 4 OF 12

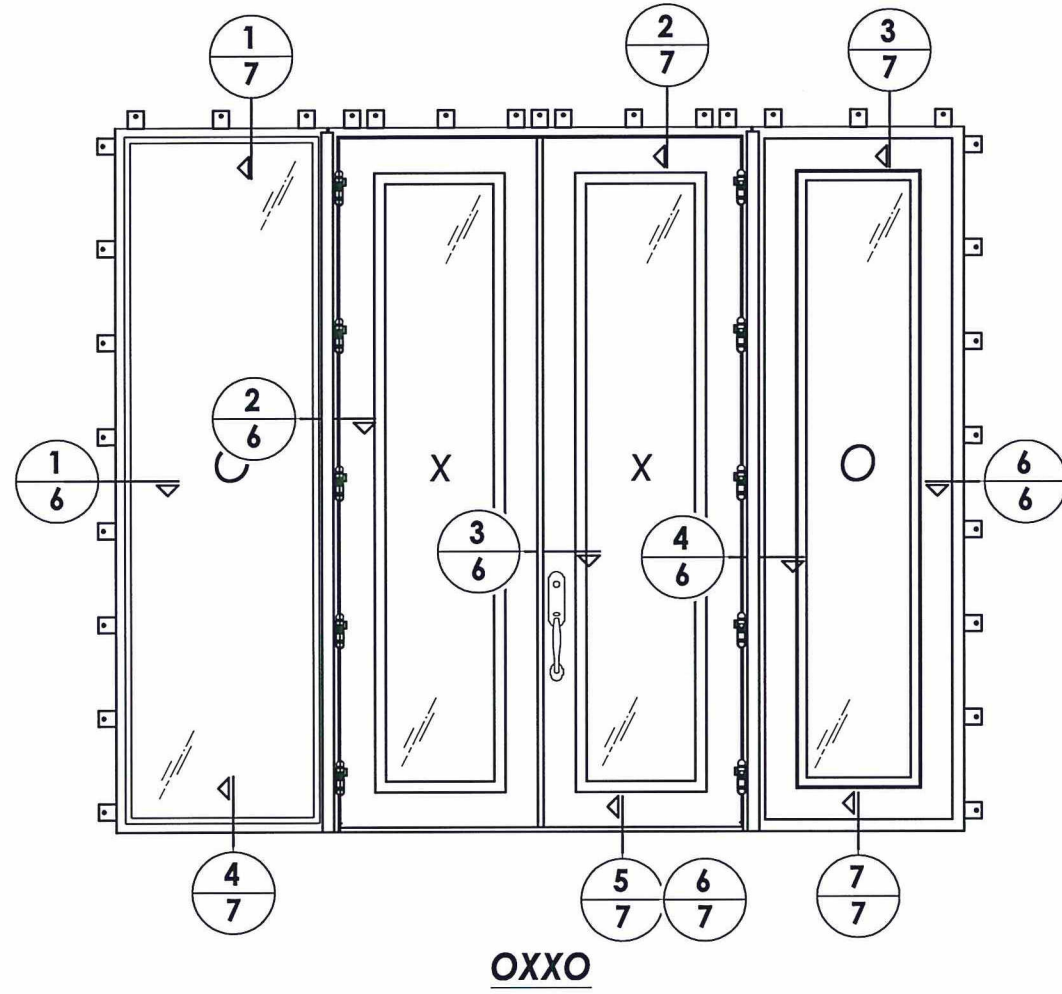
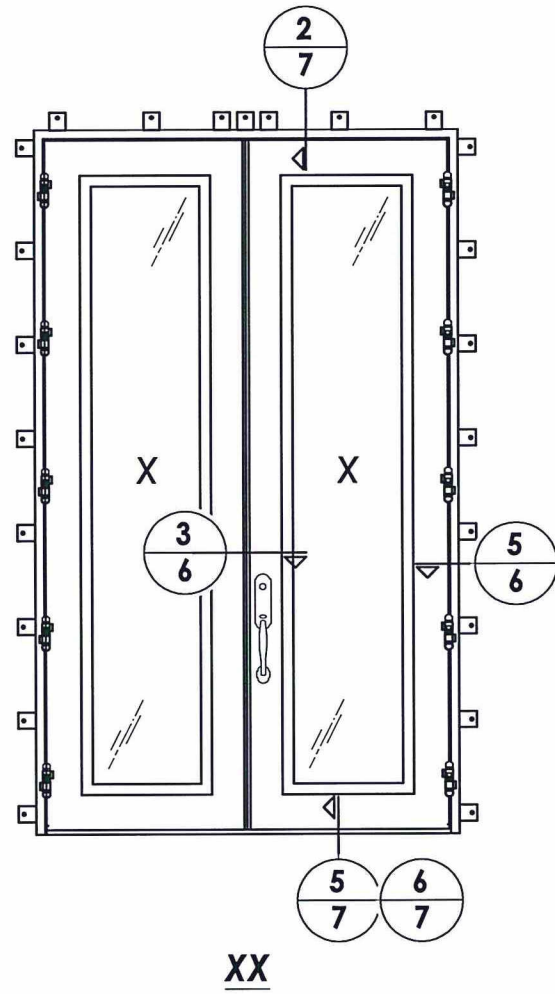

LOCK HARDWARE TABLE

MANUFACTURER	MODEL
EMTEK	TUBULAR ENTRY SET (SHERIDAN - 451812)
SUN VALLEY BRONZE ACCURATE LOCK & HARDWARE	LEVER/KNOB ENTRY SET (RIDGE: CS-421PLD) MORTISE LOCK
ASHLEY NORTON	TUBULAR ENTRY SET (SQTUB w/ 900 SERIES KNOB)
ASHLEY NORTON ACCURATE LOCK & HARDWARE	MORTISE LOCK (SQMOR w/ 900 SERIES KNOB) MORTISE LOCK

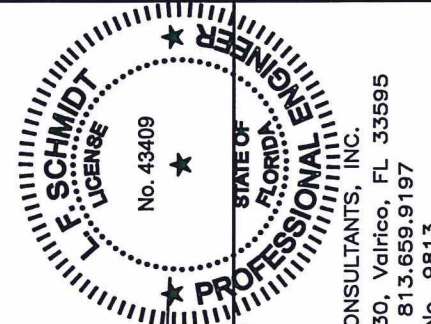

LFS
8-18-15

Documents Prepared By:
Lyndon F. Schmidt
P.E. No. 43409

RW
BUILDING CONSULTANTS, INC.
P.O. Box 230, Valrico, FL 33595
Phone No.: 813.659.9197
FBPE C.A. No. 9813

PRODUCT: CLARK HALL IRON DOORS

PART OR ASSEMBLY: ELEVATIONS

NO.	DATE	DESCRIPTION	BY
1	8/17/15	UPDATE TO 5TH ED. (2014) FBC	LFS
REVISIONS			

DATE: 10/30/13

SCALE: N.T.S.

DWG. BY: JK

CHK. BY: LFS

DRAWING NO.: FL-16663.5

SHEET 5 OF 12

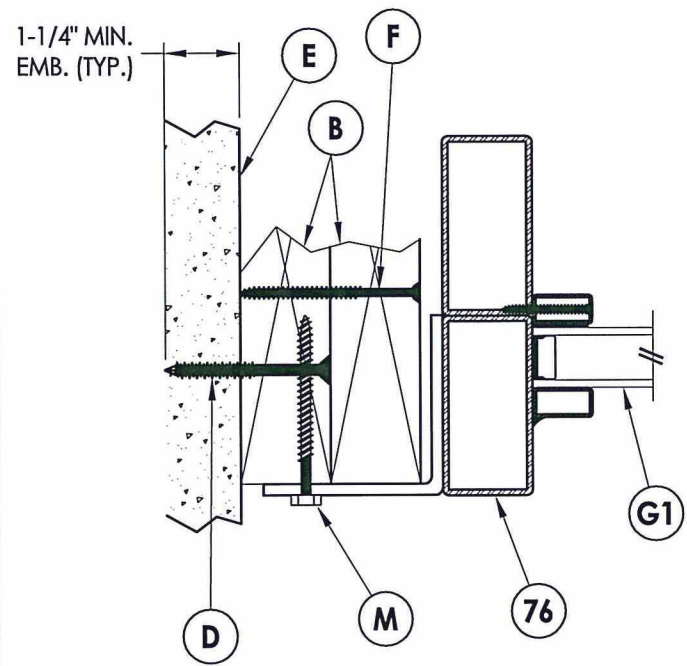

1 HORIZONTAL CROSS SECTION
6

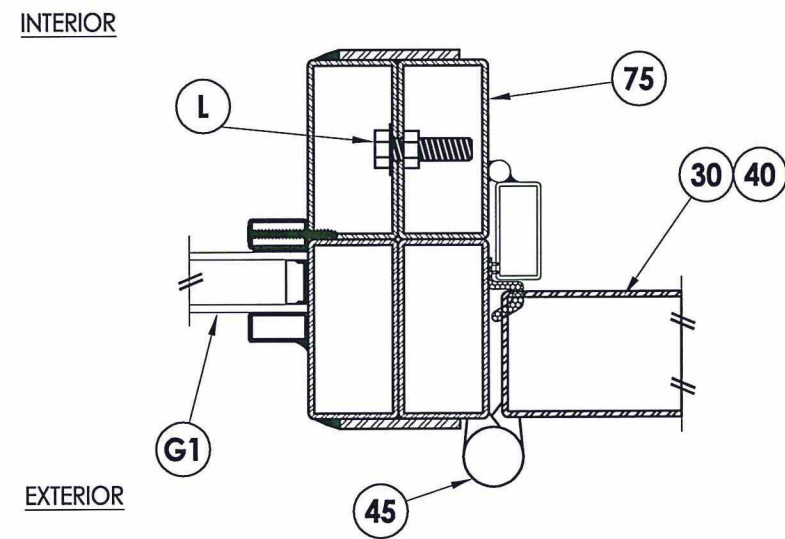

2 HORIZONTAL CROSS SECTION
6 Outswing Shown (Inswing Similar)

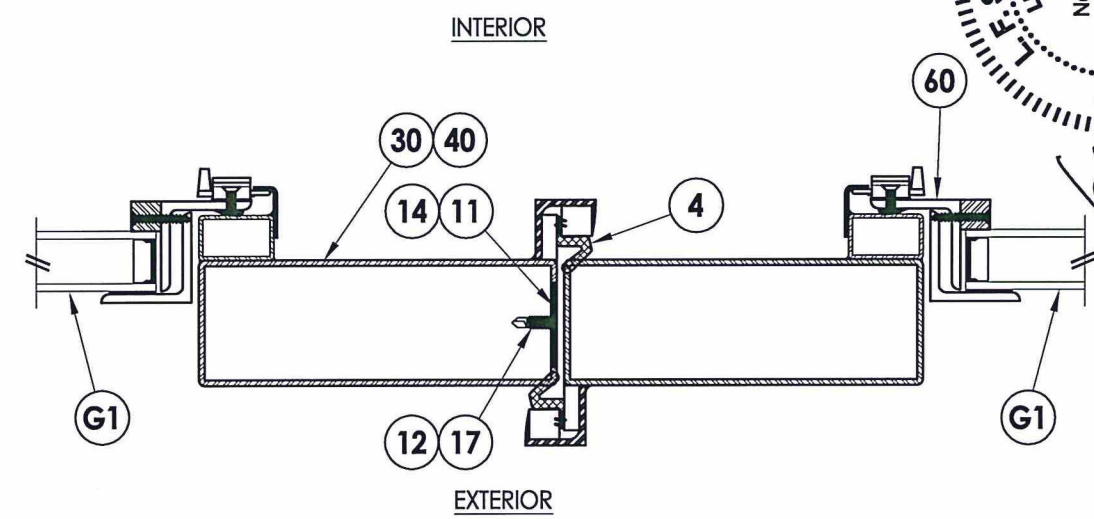

3 HORIZONTAL CROSS SECTION
6 Outswing Shown (Inswing Similar)

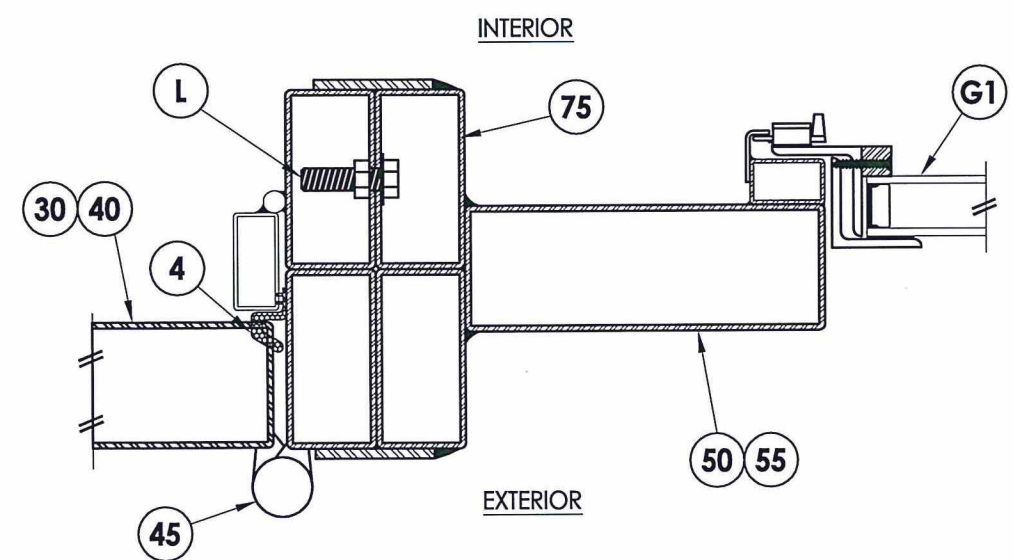

4 HORIZONTAL CROSS SECTION
6 Outswing Shown (Inswing Similar)

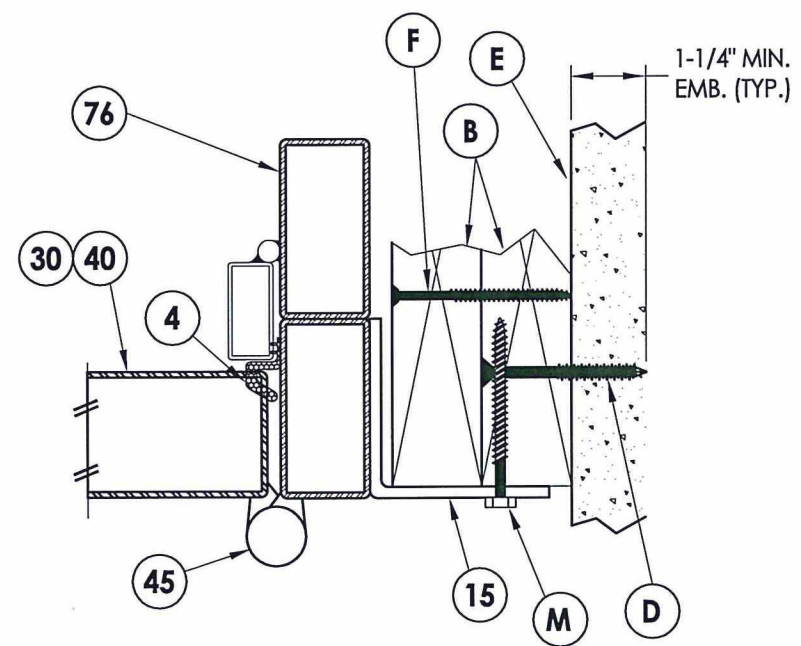

5 HORIZONTAL CROSS SECTION
6 Outswing Shown (Inswing Similar)

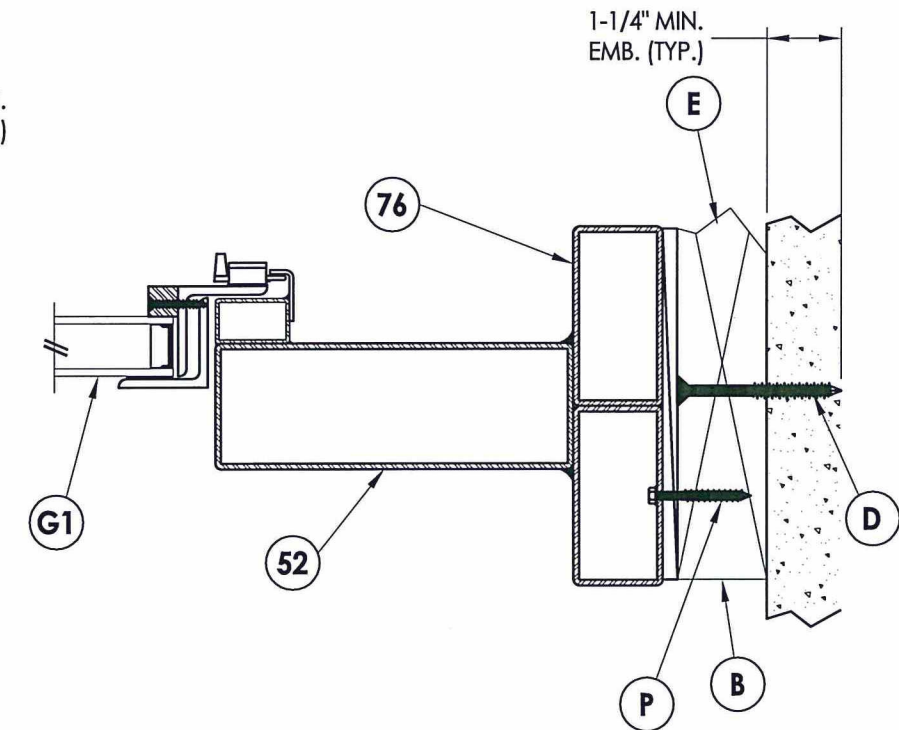

6 HORIZONTAL CROSS SECTION
6 Shown w/ Optional Through the Frame Anchoring

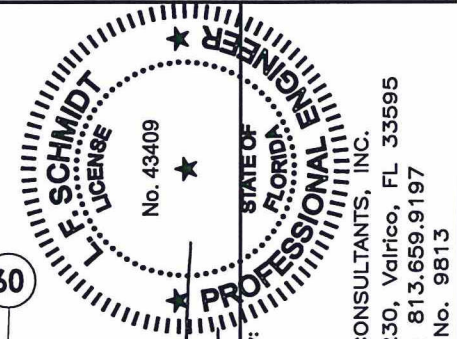

Documents Prepared By:
Lyndon F. Schmidt
P.E. No. 43409

R.W. BUILDING CONSULTANTS, INC.
P.O. Box 230, Vairico, FL 33595
Phone No.: 813.659.9197
FBPE C.A. No. 9813

PRODUCT: CLARK HALL IRON DOORS

PART OR ASSEMBLY:
HORIZONTAL CROSS SECTIONS

NO.	DATE	BY	LFS
1	8/17/15	DATE	UPDATE TO 5TH ED. (2014) FBC

DATE:	10/30/13
SCALE:	N.T.S.
DWG. BY:	JK
CHK. BY:	LFS
DRAWING NO.:	FL-16663.5
SHEET	6 OF 12

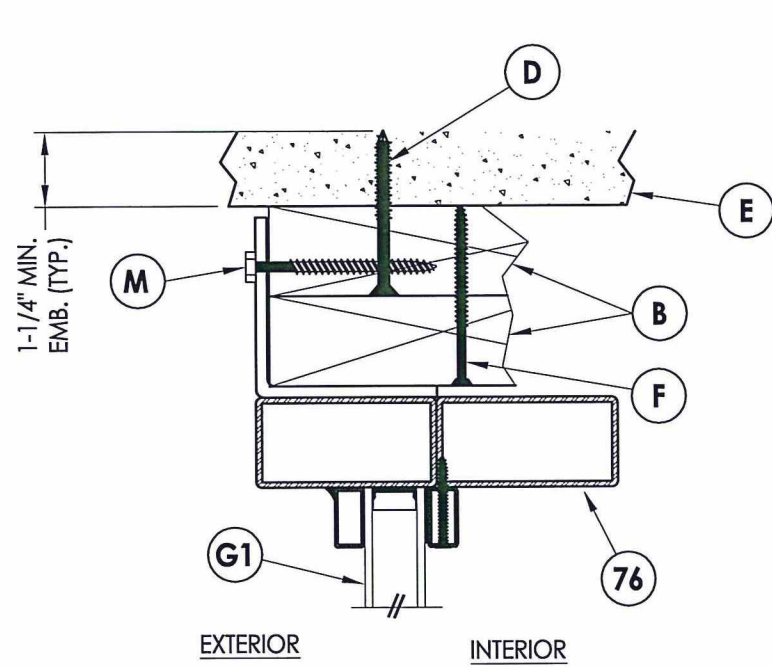

1
7 **VERTICAL CROSS SECTION**
 Outswing Shown (Inswing Similar)

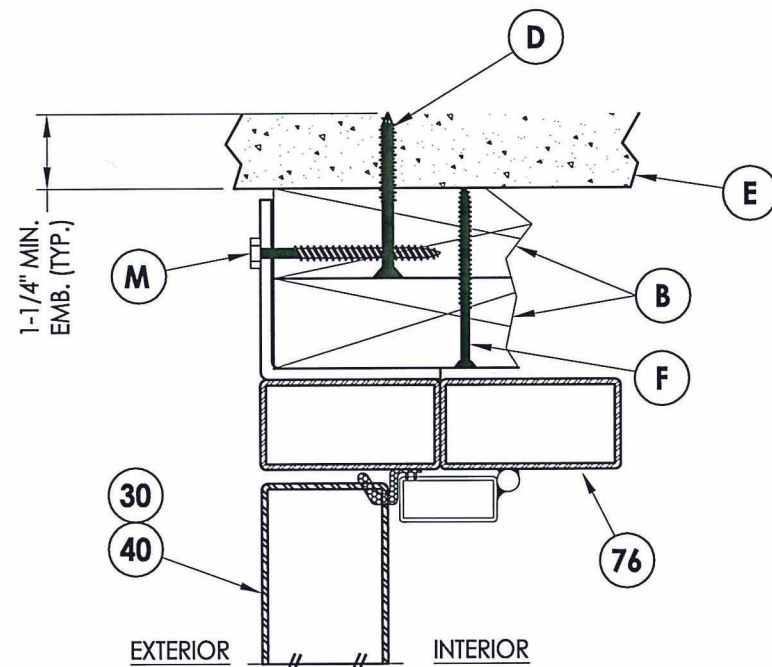

2
7 **VERTICAL CROSS SECTION**
 Outswing Shown (Inswing Similar)

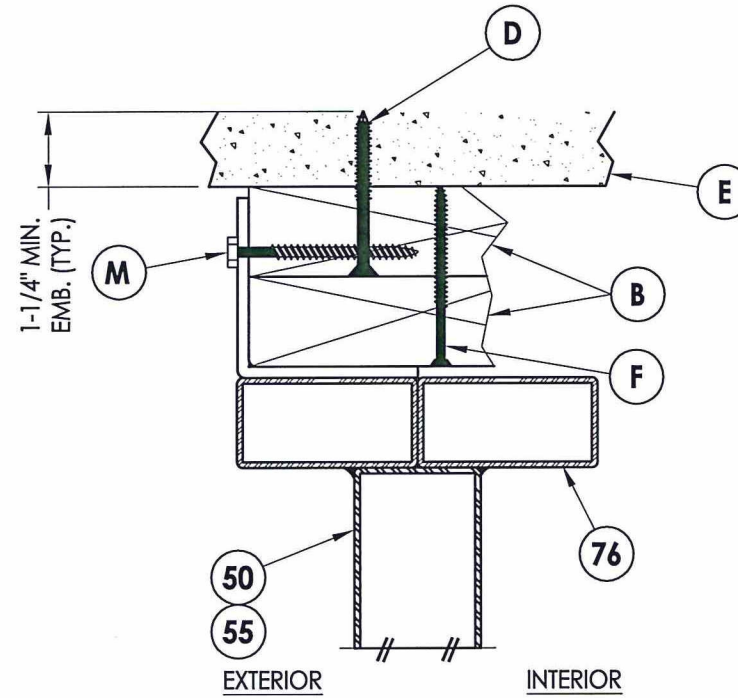

3
7 **VERTICAL CROSS SECTION**
 Outswing Shown (Inswing Similar)

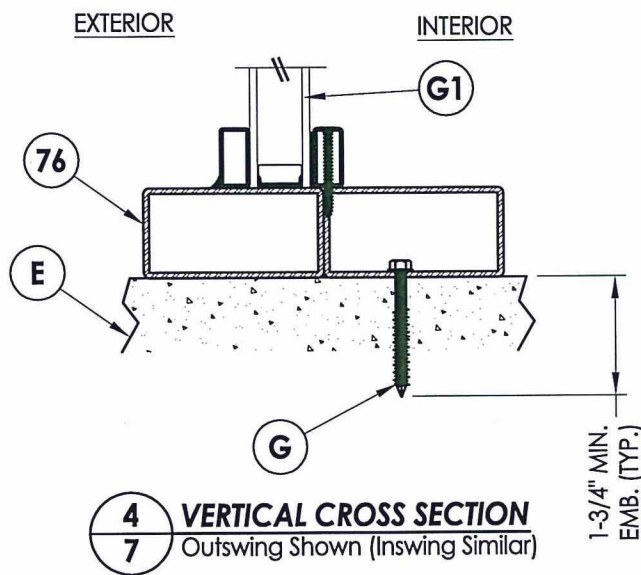

4
7 **VERTICAL CROSS SECTION**
 Outswing Shown (Inswing Similar)

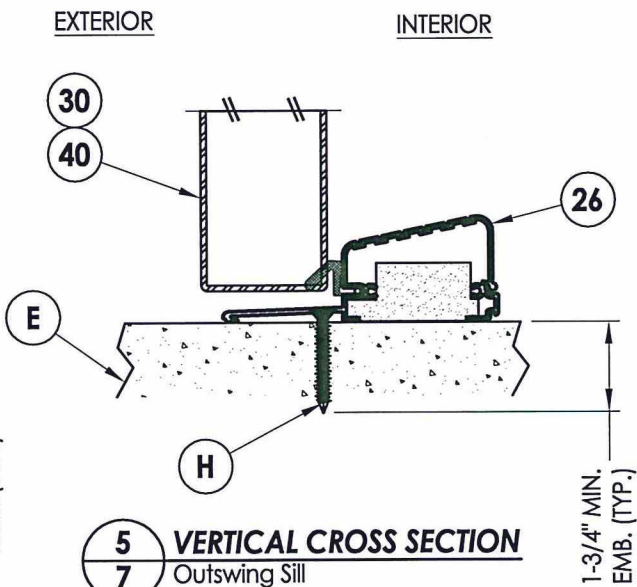

5
7 **VERTICAL CROSS SECTION**
 Outswing Sill

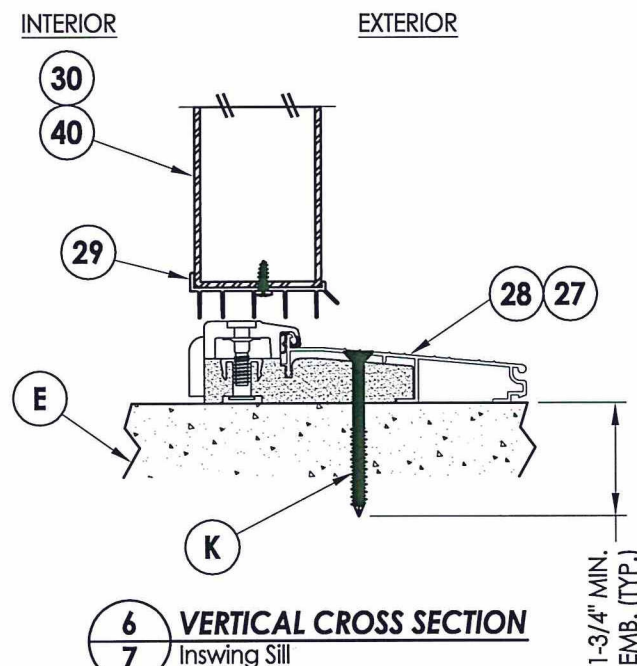

6
7 **VERTICAL CROSS SECTION**
 Inswing Sill

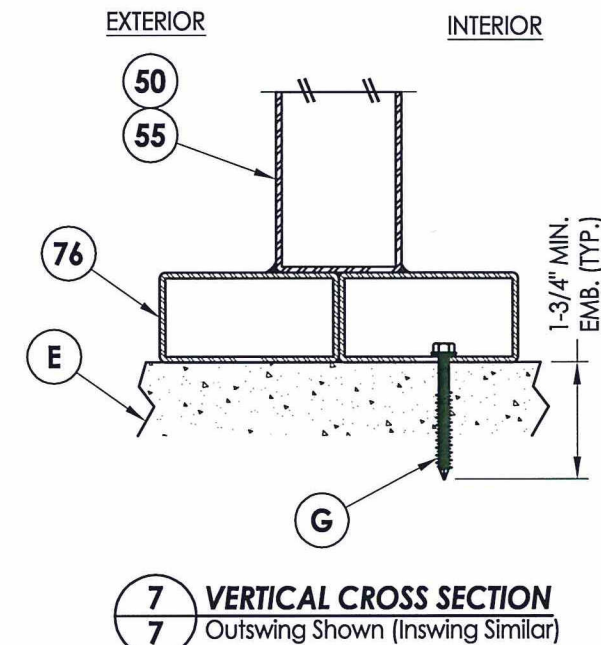

7
7 **VERTICAL CROSS SECTION**
 Outswing Shown (Inswing Similar)

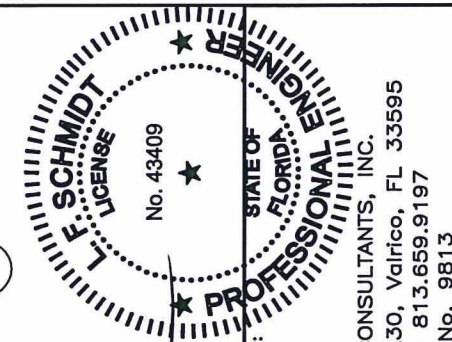

LFS
 8-18-15

Documents Prepared By:
 Lyndon F. Schmidt
 P.E. No. 43409

R.W.
 BUILDING CONSULTANTS, INC.
 P.O. Box 230, Vairico, FL 33595
 Phone No.: 813.659.9197
 FBPE C.A. No. 9813

PRODUCT: CLARK HALL IRON DOORS
 PART OR ASSEMBLY: VERTICAL CROSS SECTIONS

NO.	DATE	BY
1	8/17/15	LFS
	UPDATE TO 5TH ED. (2014) FBC	BY

DATE: 10/30/13
 SCALE: N.T.S.
 DWG. BY: JK
 CHK. BY: LFS
 DRAWING NO.: FL-16663.5
 SHEET 7 OF 12

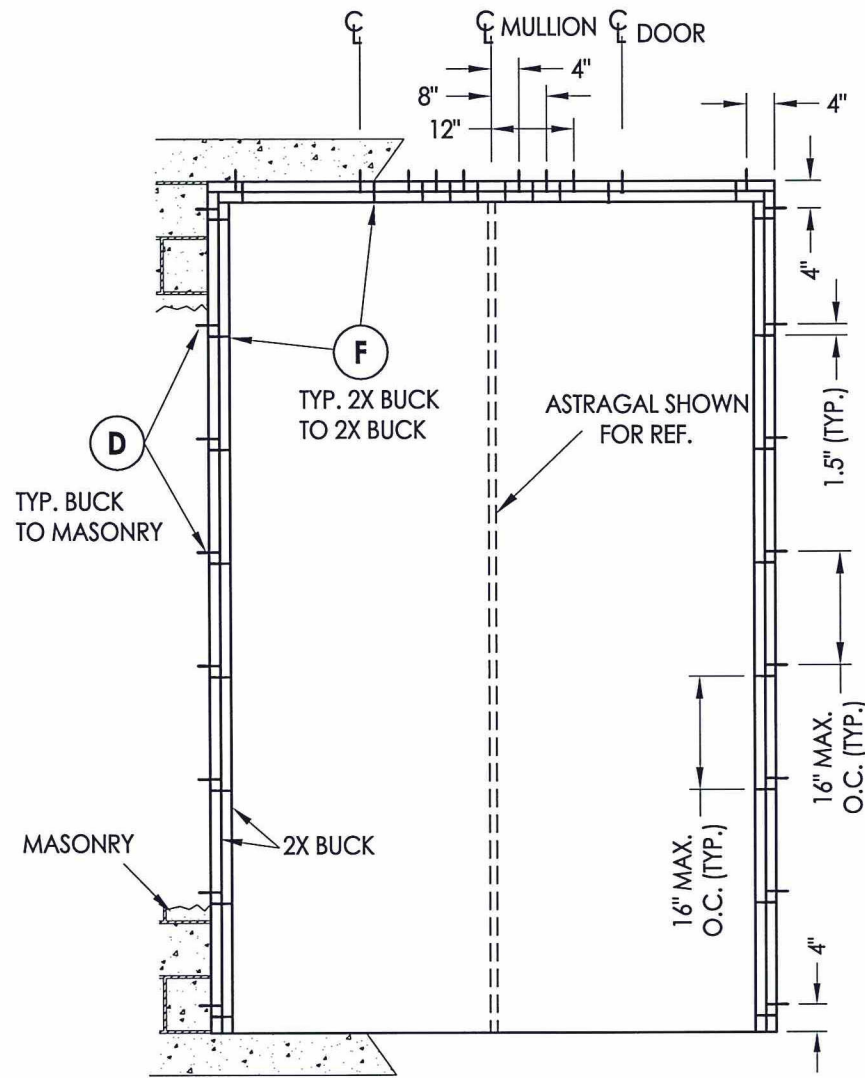

BUCK ANCHORING
XX

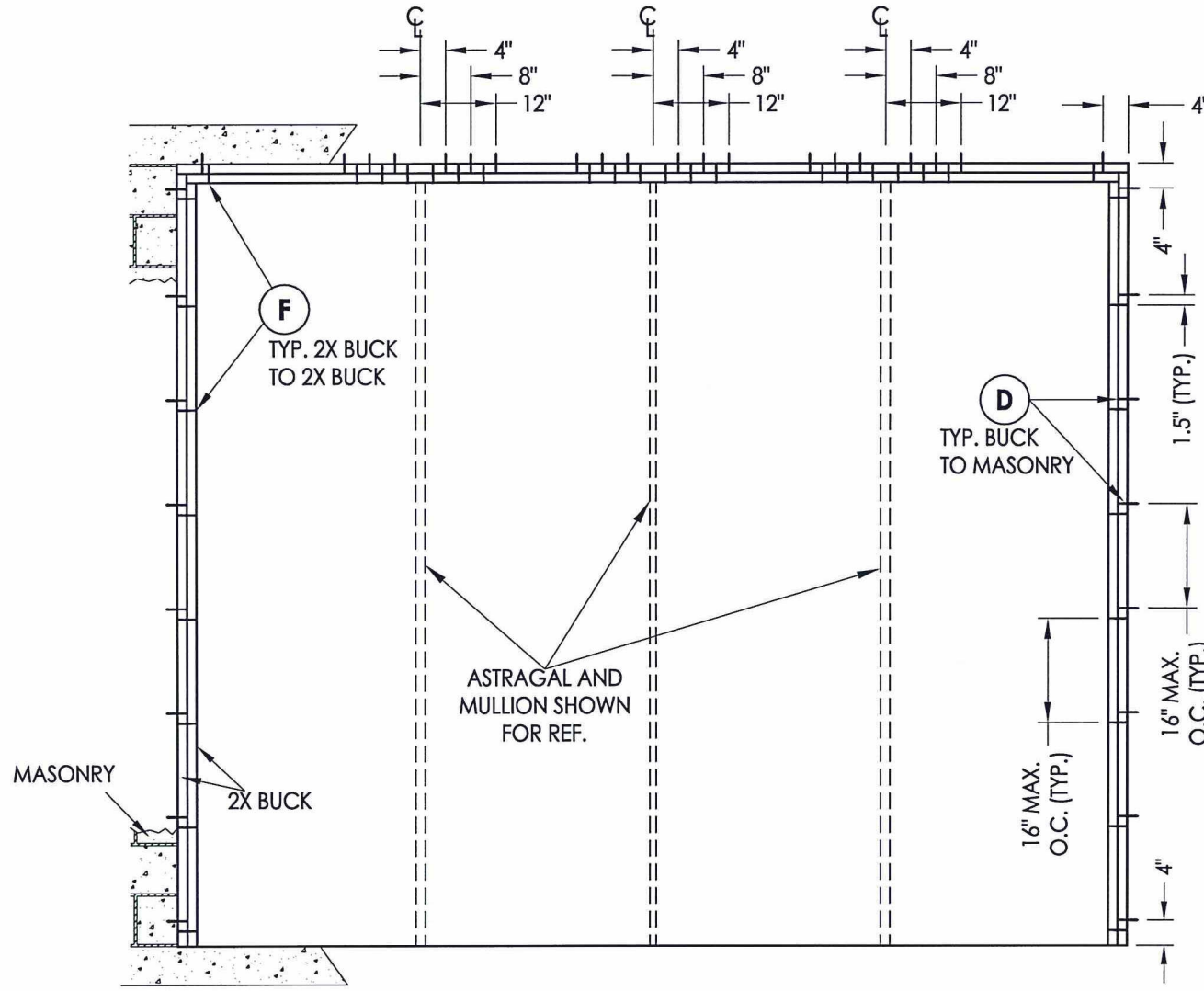

BUCK ANCHORING
OXXO

NOTE FOR THROUGH THE FRAME ANCHORING ONLY
ONE 2X BUCK IS REQUIRED, ANCHORED AS SHOWN.

CONCRETE ANCHOR NOTES:

- Concrete anchor locations at the corners may be adjusted to maintain the min. edge distance to mortar joints.
- Concrete anchor locations noted as "MAX. ON CENTER" must be adjusted to maintain the min. edge distance to mortar joints, additional concrete anchors may be required to ensure the "MAX. ON CENTER" dimension are not exceeded.
- Concrete anchor table:

ANCHOR TYPE	ANCHOR SIZE	MIN. EMBEDMENT	MIN. CLEARANCE TO MASONRY EDGE	MIN. CLEARANCE TO ADJACENT ANCHOR
ITW TAPCON®	1/4"	1-1/4"	2-1/2"	4"
ELCO ULTRACON®	1/4"	1-1/4"	2-1/2"	4"

WOOD SCREW INSTALLATION NOTES:

Maintain a minimum 5/8" edge distance, 1" end distance, & 1" o.c. spacing of wood screws to prevent the splitting of wood.

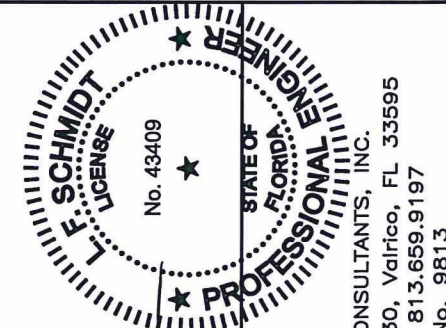

Documents Prepared By:
Lyndon F. Schmidt
P.E. No. 43409

R.W. BUILDING CONSULTANTS, INC.
P.O. Box 230, Vairico, FL 33595
Phone No.: 813.659.9197
FBPE C.A. No. 9813

PRODUCT:	CLARK HALL IRON DOORS
PART OR ASSEMBLY:	BUCK ANCHORING
DATE:	10/30/13
SCALE:	N.T.S.
DWG. BY:	JK
CHK. BY:	LFS
DRAWING NO.:	FL-16663.5
SHEET	8 OF 12

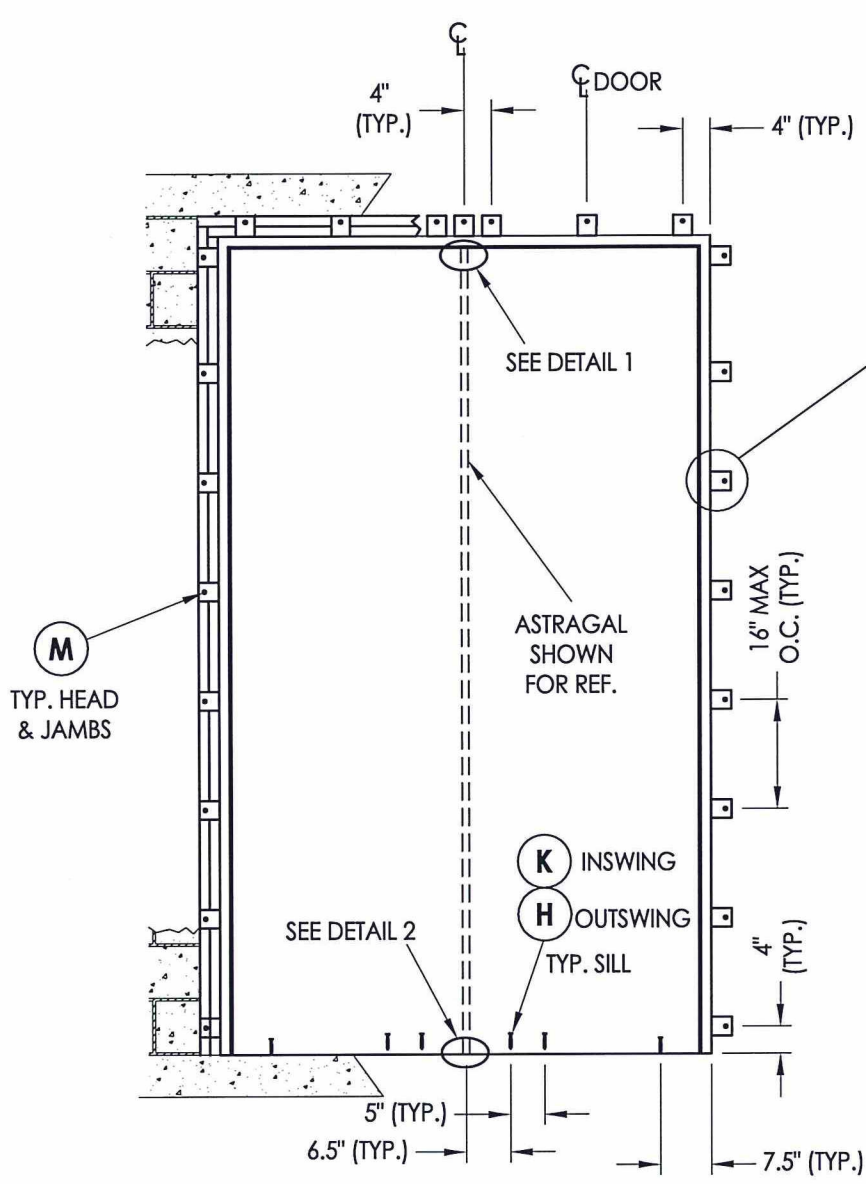

ALTERNATE ANCHORING
 THROUGH THE FRAME
 SUBSTITUTE ANCHOR @ EACH BRACKET

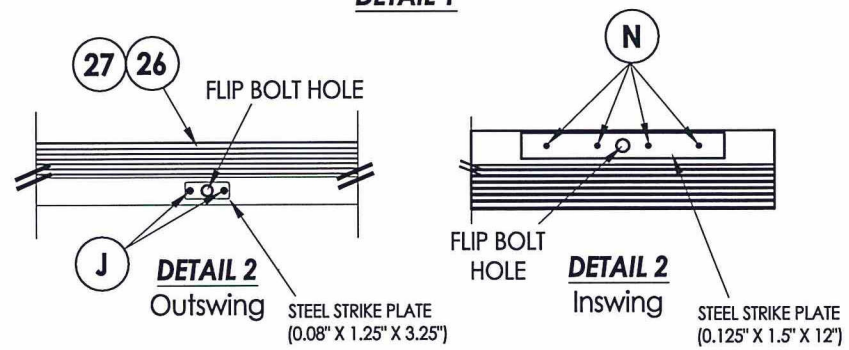
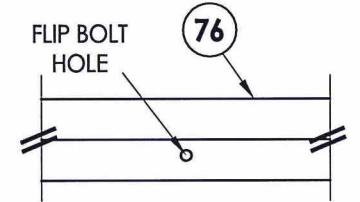
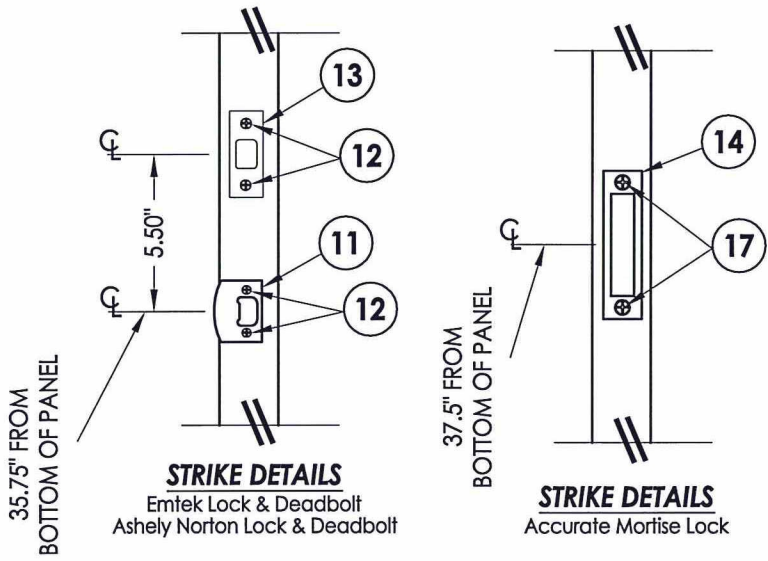
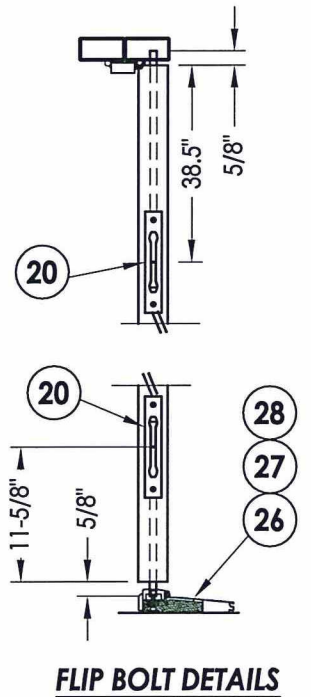

CONCRETE ANCHOR NOTES:

- Concrete anchor locations at the corners may be adjusted to maintain the min. edge distance to mortar joints.
- Concrete anchor locations noted as "MAX. ON CENTER" must be adjusted to maintain the min. edge distance to mortar joints, additional concrete anchors may be required to ensure the "MAX. ON CENTER" dimension are not exceeded.
- Concrete anchor table:

ANCHOR TYPE	ANCHOR SIZE	MIN. EMBEDMENT	MIN. CLEARANCE TO MASONRY EDGE	MIN. CLEARANCE TO ADJACENT ANCHOR
ITW TAPCON®	3/16"	1-1/4"	3"	2-1/2"
	1/4"	1-1/4"	2-1/2"	4"
	5/16" (XL)	1-3/4"	2-1/2"	5"
ELCO ULTRACON®	1/4"	1-1/4"	2-1/2"	4"
	5/16"	1-3/4"	2-1/2"	5"

WOOD SCREW INSTALLATION NOTES:

Maintain a minimum 5/8" edge distance, 1" end distance, & 1" o.c. spacing of wood screws to prevent the splitting of wood.

E. SCHMIDT
 LICENSE
 No. 43409
 STATE OF FLORIDA
PROFESSIONAL ENGINEER

Documents Prepared By:
 Lyndon F. Schmidt
 P.E. No. 43409

R.W.
 BUILDING CONSULTANTS, INC.
 P.O. Box 230, Vairico, FL 33595
 Phone No.: 813.659.9197
 FBPE C.A. No. 9813

PRODUCT:	CLARK HALL IRON DOORS		
PART OR ASSEMBLY:	FRAME ANCHORING		
DATE:	10/30/13	BY:	LFS
DWG. BY:	JK	DATE:	8/17/15
CHK. BY:	LFS	UPDATE TO:	5TH ED. (2014) FBC
DRAWING NO.:	FL-16663.5	NO.:	1
SHEET	9	OF	12

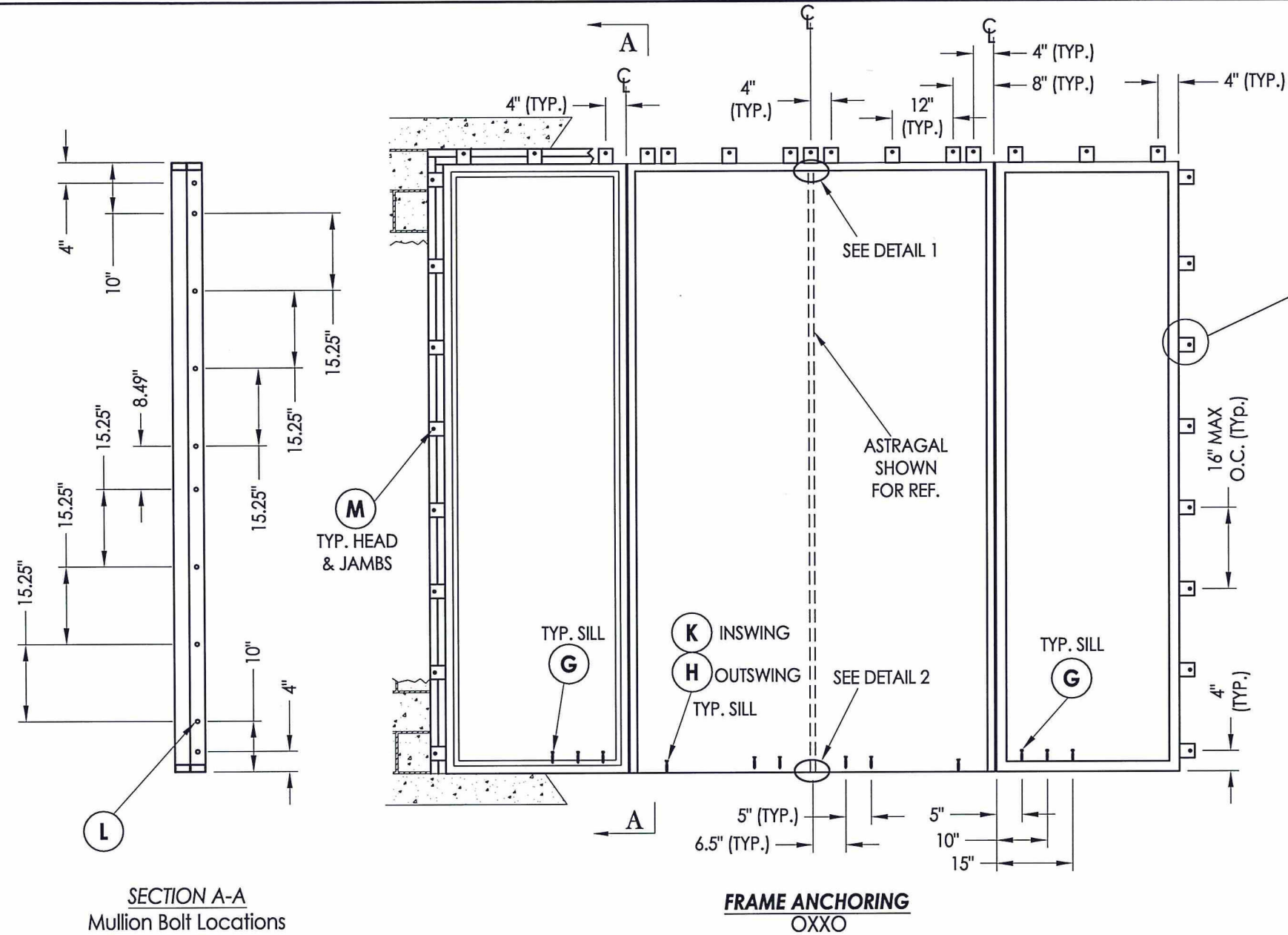

ALTERNATE ANCHORING
THROUGH THE FRAME
SUBSTITUTE ANCHOR @ EACH BRACKET

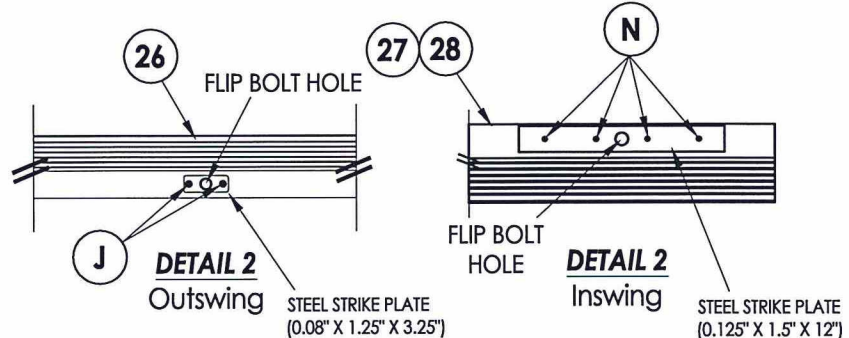
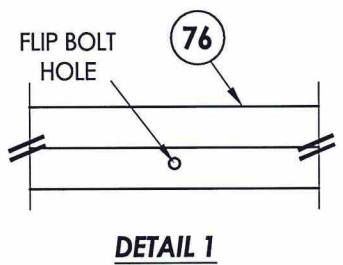
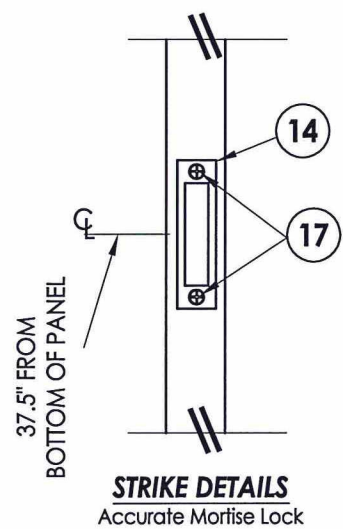
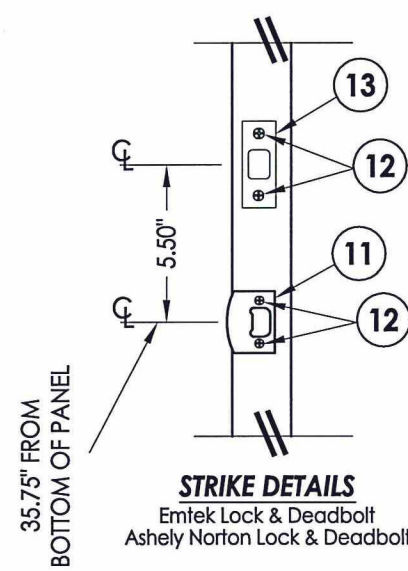
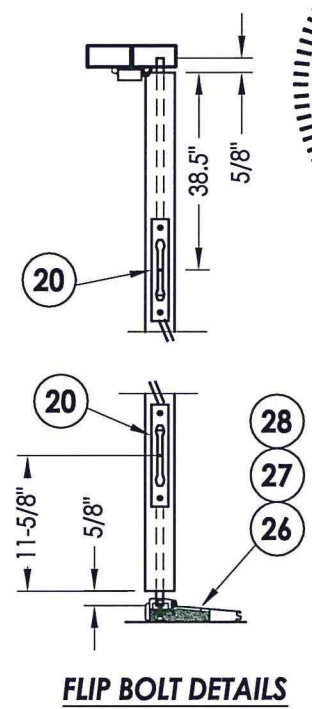
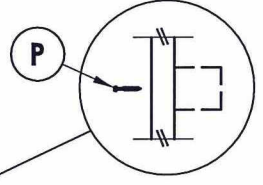

- CONCRETE ANCHOR NOTES:**
- Concrete anchor locations at the corners may be adjusted to maintain the min. edge distance to mortar joints.
 - Concrete anchor locations noted as "MAX. ON CENTER" must be adjusted to maintain the min. edge distance to mortar joints, additional concrete anchors may be required to ensure the "MAX. ON CENTER" dimension are not exceeded.
 - Concrete anchor table:

ANCHOR TYPE	ANCHOR SIZE	MIN. EMBEDMENT	MIN. CLEARANCE TO MASONRY EDGE	MIN. CLEARANCE TO ADJACENT ANCHOR
ITW TAPCON®	3/16"	1-1/4"	3"	2-1/2"
	1/4"	1-1/4"	2-1/2"	4"
	5/16" (XL)	1-3/4"	2-1/2"	5"
ELCO ULTRACON®	1/4"	1-1/4"	2-1/2"	4"
	5/16"	1-3/4"	2-1/2"	5"

- WOOD SCREW INSTALLATION NOTES:**
Maintain a minimum 5/8" edge distance, 1" end distance, & 1" o.c. spacing of wood screws to prevent the splitting of wood.

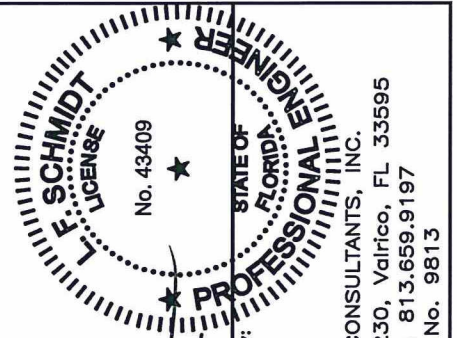

Documents Prepared By:
Lyndon F. Schmidt
P.E. No. 43409

R.W. BUILDING CONSULTANTS, INC.
P.O. Box 230, Valrico, FL 33595
Phone No.: 813.659.9197
FBPE C.A. No. 9813

PRODUCT:	CLARK HALL IRON DOORS
PART OR ASSEMBLY:	FRAME ANCHORING
DATE:	10/30/13
SCALE:	N.T.S.
DWG. BY:	JK
CHK. BY:	LFS
DRAWING NO.:	FL-16663.5
SHEET	10 OF 12

\\Clients\Clark Hall Iron Doors PERMANENT\A - Florida Product Approvals\FL-16663 Exterior Doors - Iron Doors\C - Drawings\FL 16663 (2014)\FL-16663.4-6.dwg, 1.1.5

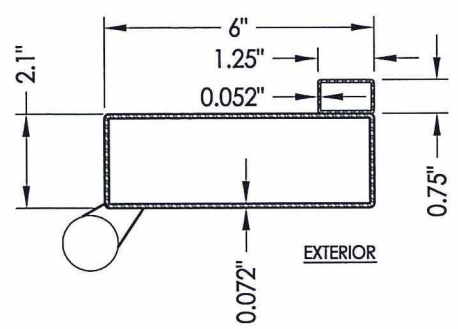

41 Full Life Door Panel
Inactive Hinge Stile

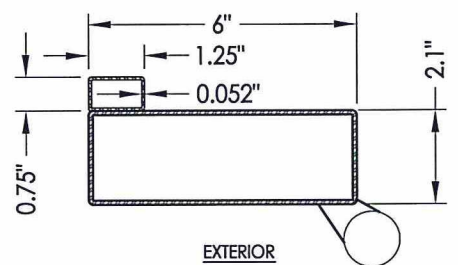

31 Full Life Door Panel
Active Hinge Stile

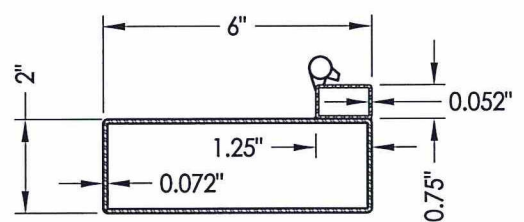

51 Sidelite Panel
Operable Sash Hinge Stile

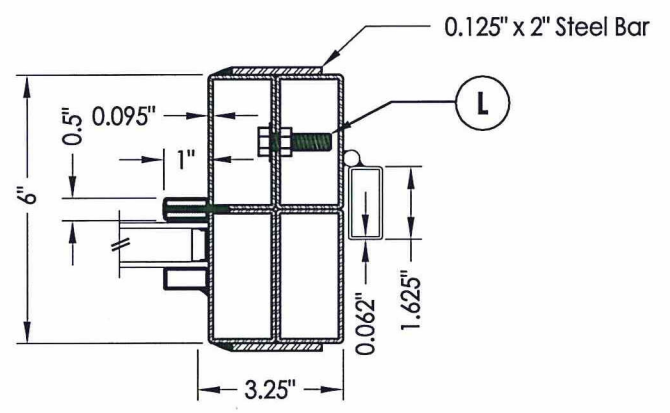

75 Vertical Mull
with Direct Set Sidelite

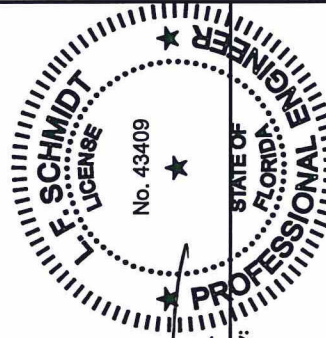

Documents Prepared By:
Lyndon F. Schmidt
P.E. No. 43409
R.W. BUILDING CONSULTANTS, INC.
P.O. Box 230, Valrico, FL 33595
Phone No.: 813.659.9197
FBPE C.A. No. 9813

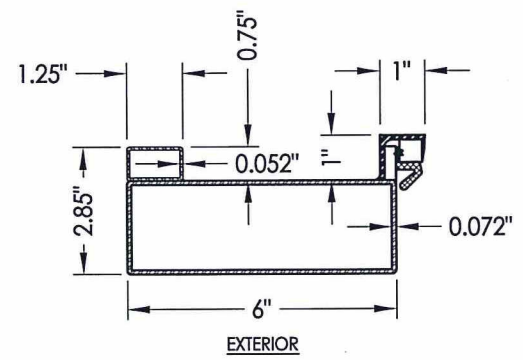

42 Full Life Door Panel
Inactive Latch Stile

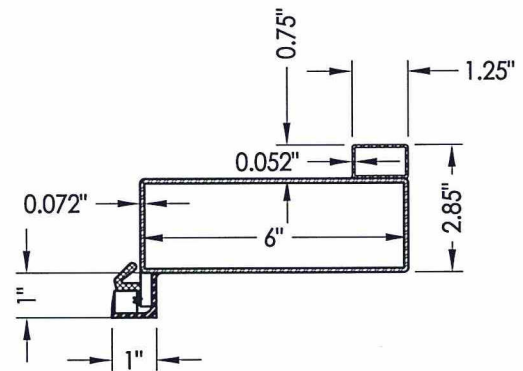

32 Full Life Door Panel
Active Latch Stile

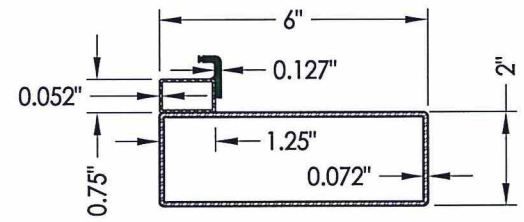

52 Sidelite Panel
Operable Sash Latch Stile

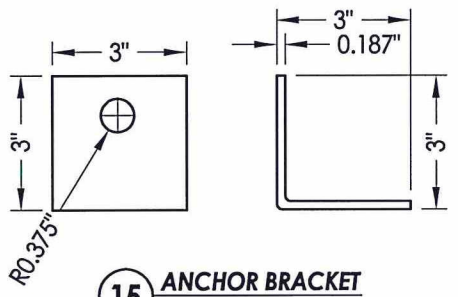

15 ANCHOR BRACKET

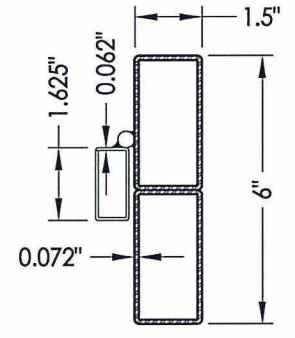

76 Jamb

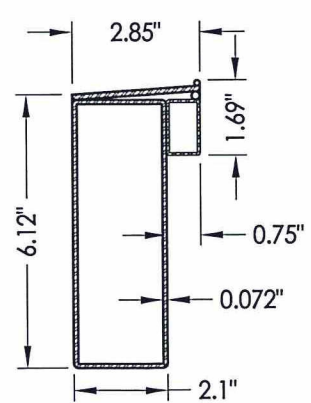

43 Full Life Door Panel
Bottom Rail

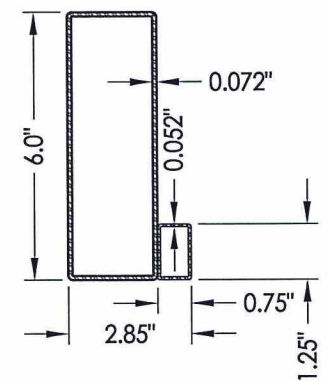

44 Full Life Door Panel
Top Rail

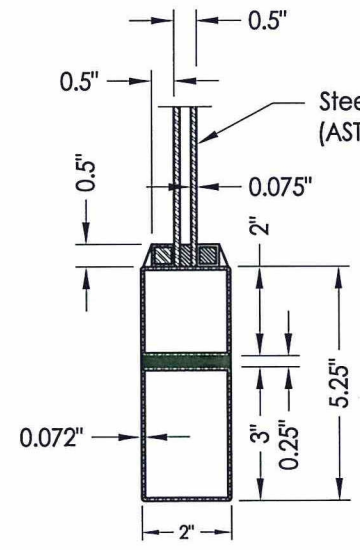

54 Bottom Rail
3/4 Lite Sidelite Panel

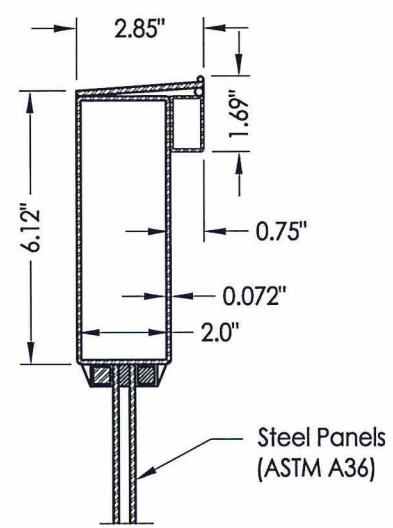

56 Mid Rail
3/4 Lite Sidelite Panel

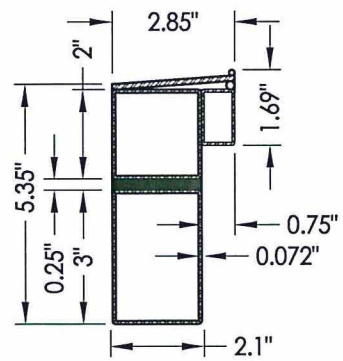

53 Bottom Rail
Sidelite Panel

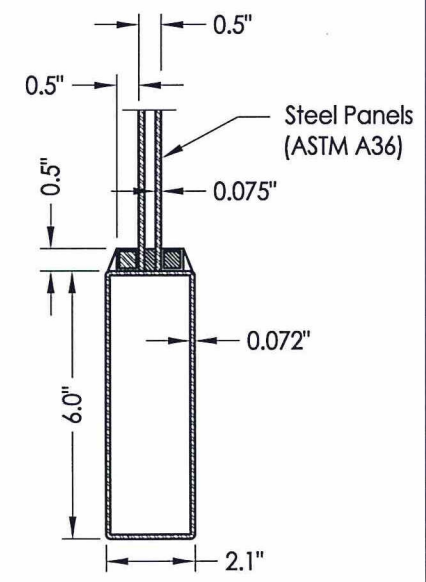

57 Bottom Rail
3/4 Lite Door Panel

PRODUCT:	CLARK HALL IRON DOORS	
PART OR ASSEMBLY:	COMPONENTS	
DATE:	10/30/13	
SCALE:	N.T.S.	
DWG. BY:	JK	
CHK. BY:	LFS	
DRAWING NO.:	FL-16663.5	
SHEET	11 OF 12	
NO.	DATE	REVISIONS
1	8/17/15	UPDATE TO 5TH ED. (2014) FBC
		LFS
		BY

